

ELECTRIC DIAGRAM

CWR 50 D-SA - 230V-1-60 SA



Power supply

ELECTRIC DIAGRAM

CWR 50 D-SA - 230V-1-60 SA

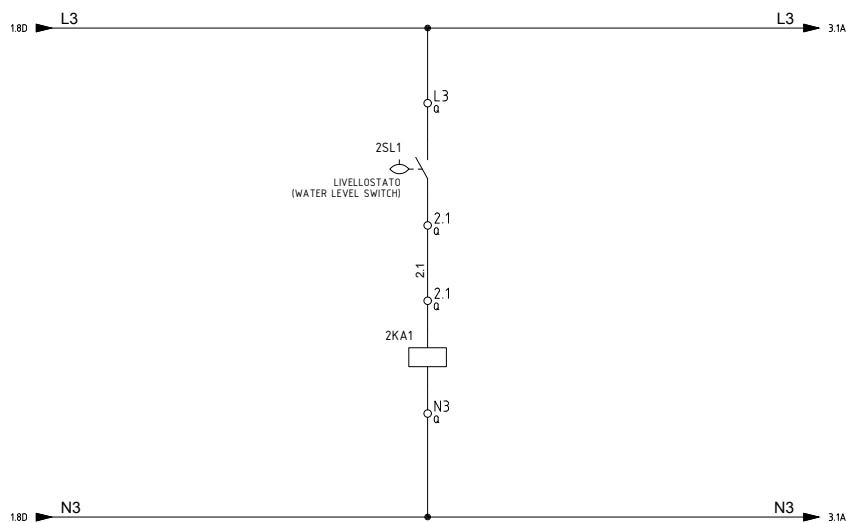

Water level switch

ELECTRIC DIAGRAM

CWR 50 D-SA - 230V-1-60 SA

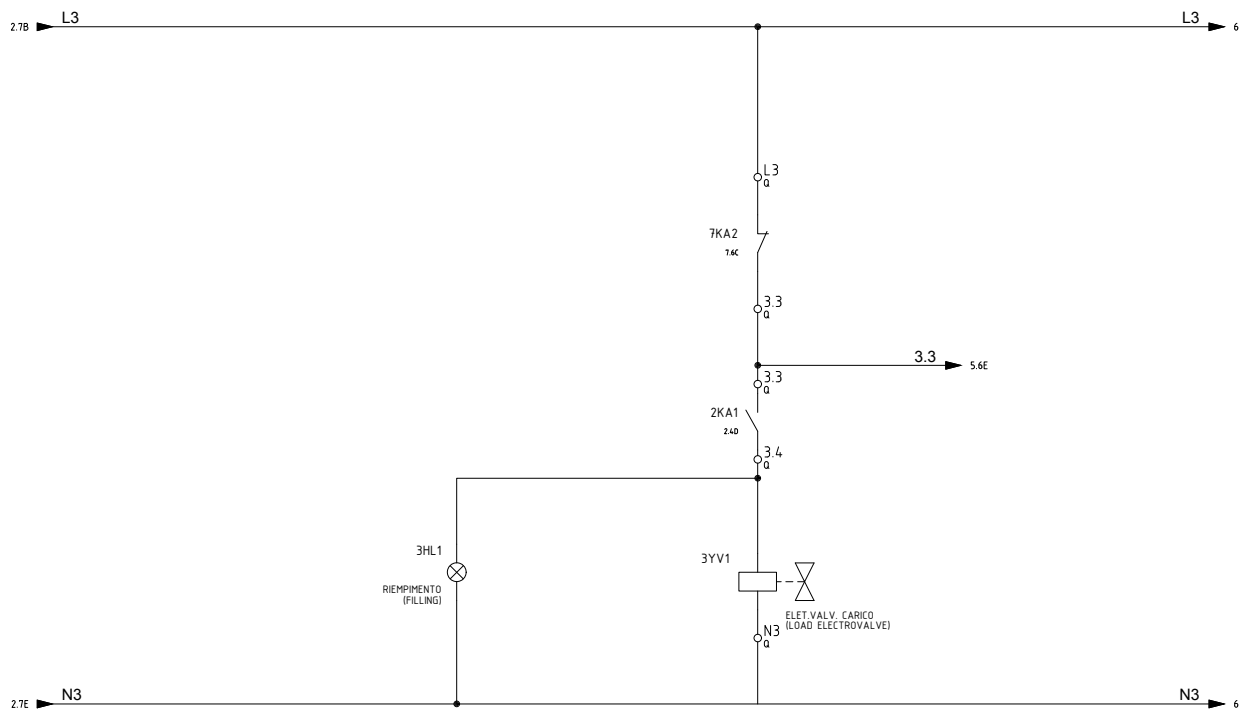

Load electro valve

ELECTRIC DIAGRAM

CWR 50 D-SA - 230V-1-60 SA

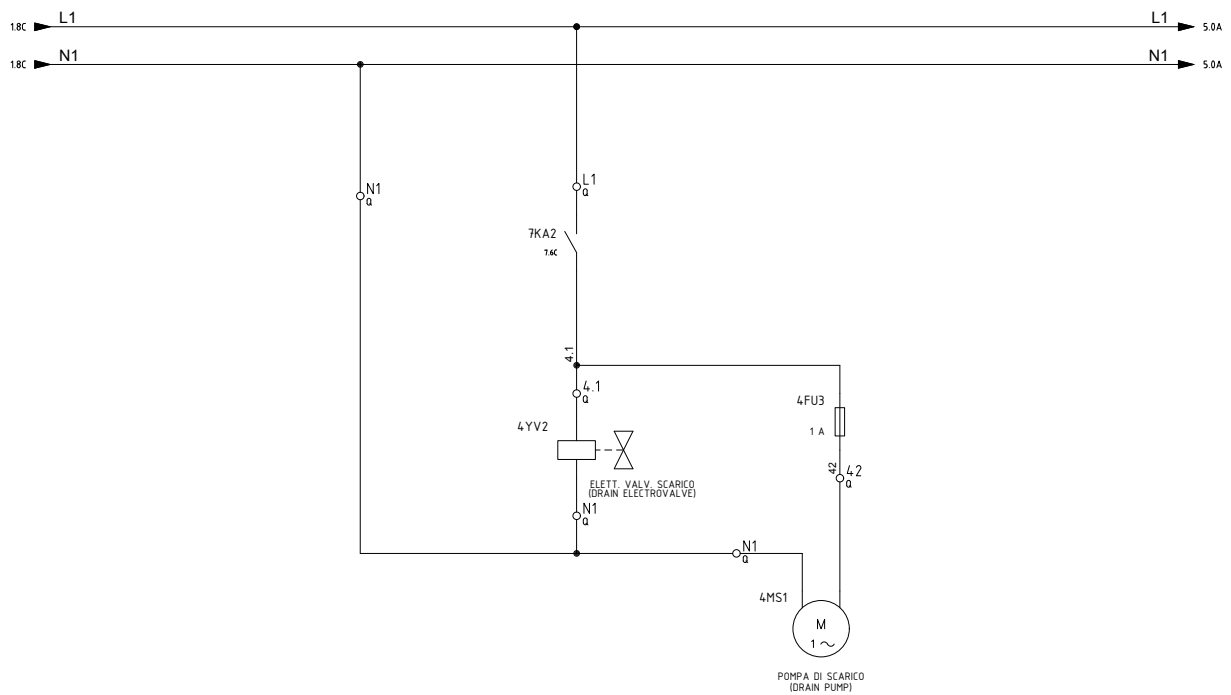

Drain electro valve+drain pump

ELECTRIC DIAGRAM

CWR 50 D-SA - 230V-1-60 SA

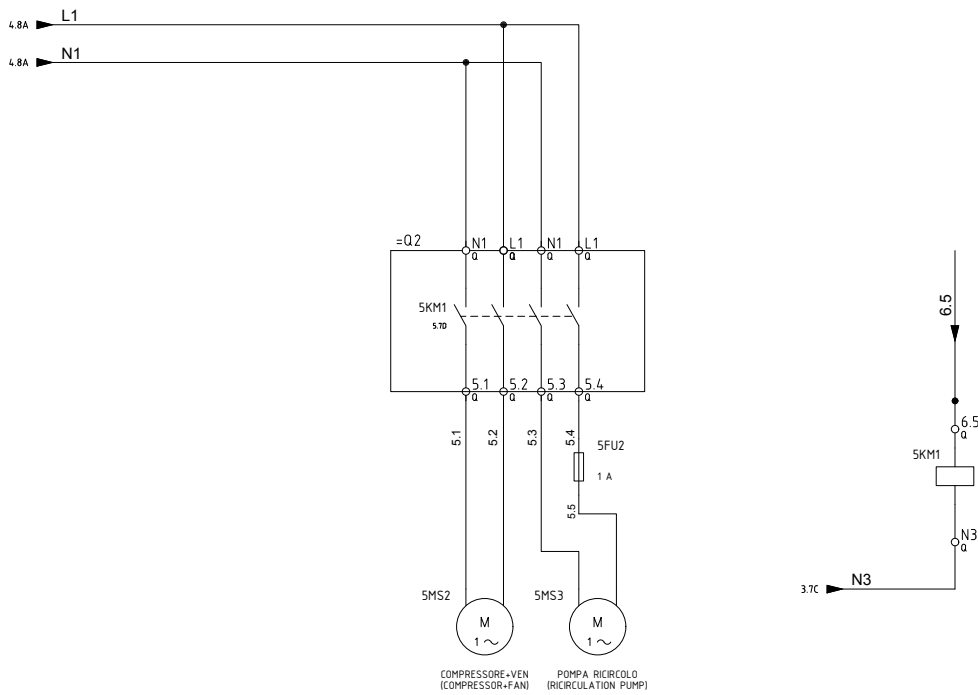

Recirculation pump+compressor+fan

ELECTRIC DIAGRAM

CWR 50 D-SA - 230V-1-60 SA

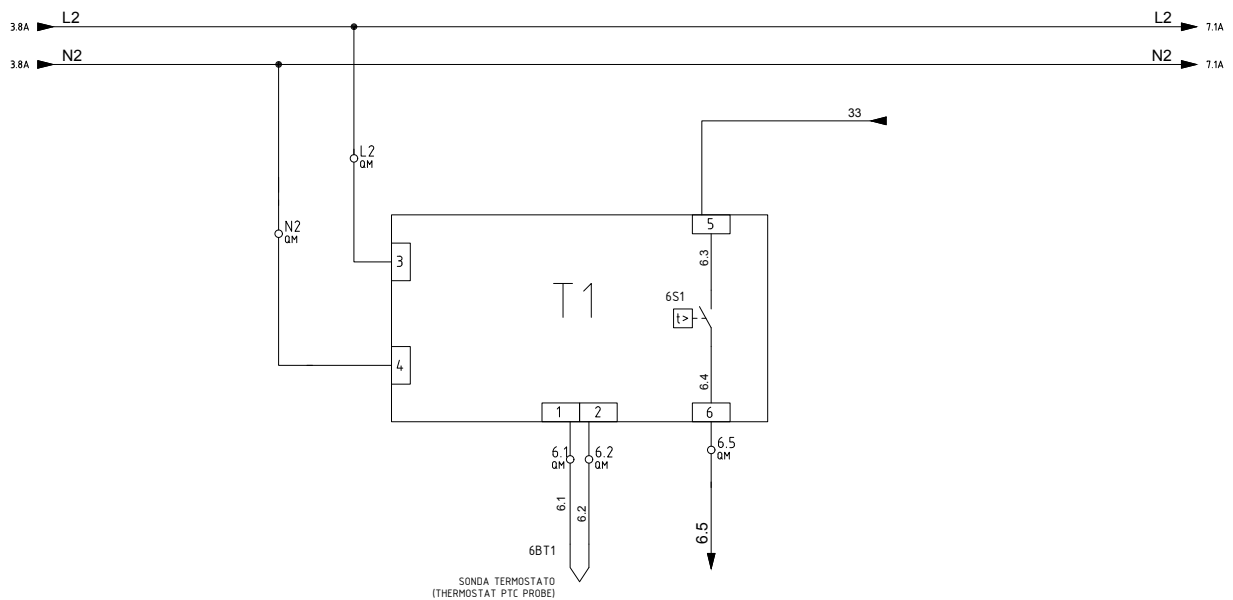

Termostato

ELECTRIC DIAGRAM

CWR 50 D-SA - 230V-1-60 SA

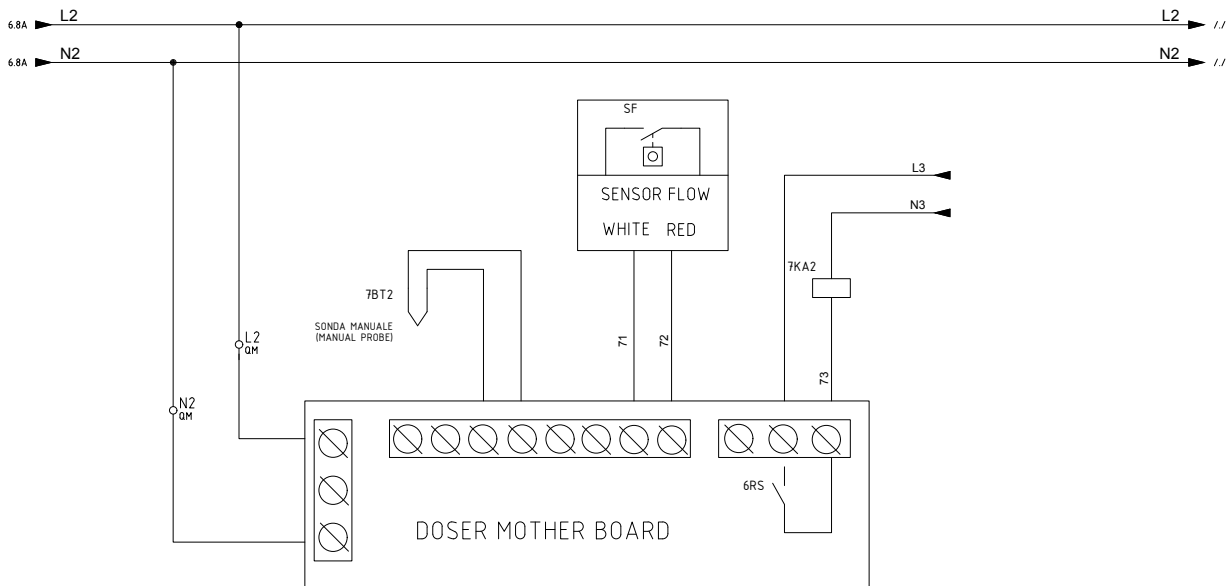

Doser mother board

ELECTRIC DIAGRAM

CWR 50 D-SA - 230V-1-60 SA

=Q2 - Q

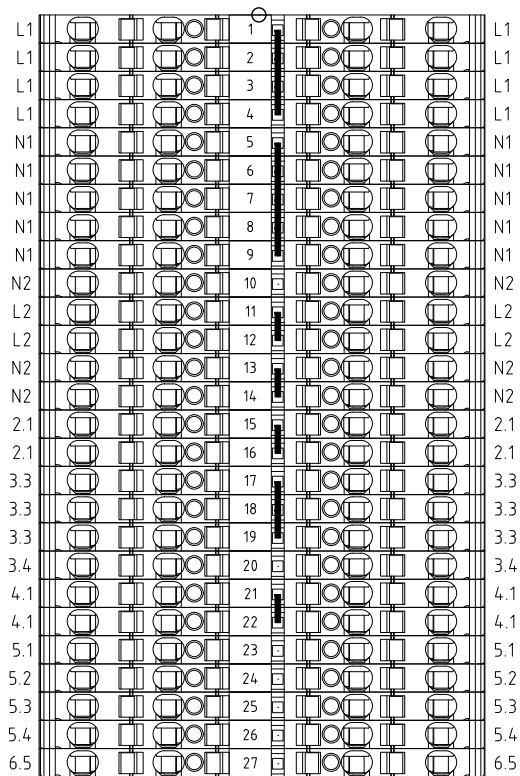

Terminal box

ELECTRIC DIAGRAM

CWR 50 D-SA - 230V-1-60 SA

Nome/Item	Tipo/Type	Descrizione/Description	Costruttore/Marke	Quadro/Board	Fg/Sh	Q.ta/Q.ty	Codice Interno
2KA1	601282300040	RELÈ INDUSTRIALE	Finder	=Q2	2	1	3600030577
ZSL1	LIVELLOSTATO ELETT.	LIVELLOSTATO ELETT.	STEM	=Q2	2	1	114.0010002
3YV1	ELETTROVALVOLA ACQUA PLAS.	ELETTROVALVOLA ACQUA PLAS.	RAGE	=Q2	3	1	24.30010003
4YV2	6700030023	ELETTROVALVOLA	CASTEL	=Q2	4	1	6700030023
5KM1	LC1K0910M7	CONT K 3P NO VITE 220 230V 50	Schneider Electric	=Q2	5	1	3600030040
Q	1683460000	Morsefio componibile di passaggio ZDU 2.5/4AN BN	Weidmuller	=Q2		24	
3C1		Condensatore		=QG	3	1	
3HL1	SPIA ROSSA 220V	SPIA ROSSA 220V Diametro 10	LALLI	=QG	3	1	3600030478
3L1		Induttore		=QG	3	1	
4MS1	24.30010004	POMPA DI RICIRCOLO	PLASET	=QG	4	1	24.30010004
5C2		Condensatore		=QG	5	1	
5L2		Induttore		=QG	5	1	
5MS2	S120 220-50	S120 220-50	UNITA COND.	=QG	5	1	3580030424
5MS3	24.30010004	POMPA DI RICIRCOLO	PLASET	=QG	5	1	24.30010004
6BT1	P1AA36P15NPS	SONDA PTC 6x30 1,5 mt	SACET	=QG	6	1	2800030415
6S1	3600030543	TERMOSTATO 6LANAN001LT	PEGO	=QG	6	1	3600030543
7BT2	SONDA A INFILZAGGIO	SONDA A INFILZAGGIO	SACET	=QG	7	1	2800030417
7KA2	601282300040	RELÈ INDUSTRIALE	Finder	=QG	7	1	3600030577
QF1	DOMA45C16	Inf. magnetof. DomA45 1P+N C 16A 4,5kA	Schneider Electric	=QG	1	1	3500030265
QS1	AV44.17	RWB Rocker Switch	Rovi	=QG	1	1	84.00010001

Materials list

ELECTRIC DIAGRAM

CWR 50 D-SA - 230V-1-60 SA



1) PORTA GUAINA

Box left view

ELECTRIC DIAGRAM

CWR 50 D-SA - 230V-1-60 SA

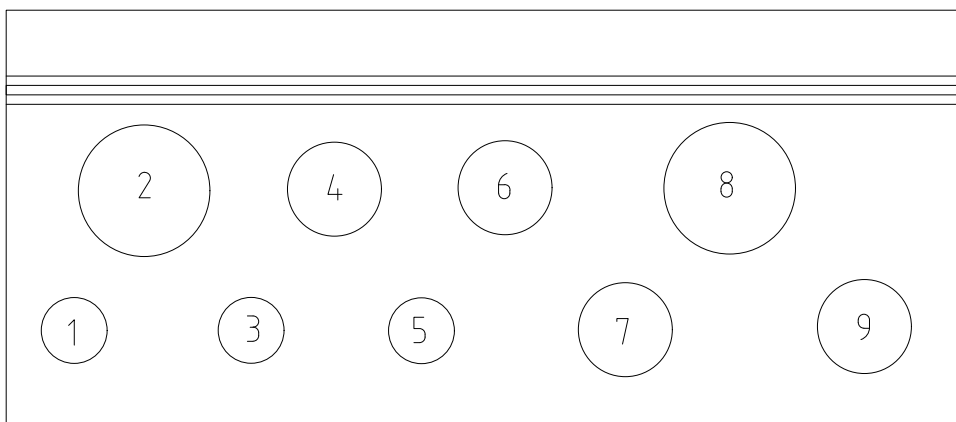

- 1) PG7 LIVELLOSTATO (WATER LEVEL SWITCH)
- 2) PG11 ALIMENTAZIONE (POWER SUPPLY)
- 3) PG7 SONDA (PROBE)
- 4) PG9 ELETTROVALVOLA DI SCARICO (DRAIN ELECTROVALVE)
- 5) PG7 SENSOR FLOW
- 6) PG9 POMPA RICIRCOLO (RICIRCULATION PUMP)
- 7) PG9 POMPA SCARICO (DRAIN PUMP)
- 8) PG11 COMPRESSORE (COMPRESSOR)
- 9) PG9 ELETTROVALVOLA DI CARICO (LOAD ELECTROVALVE)

Box right view